

E Fount.

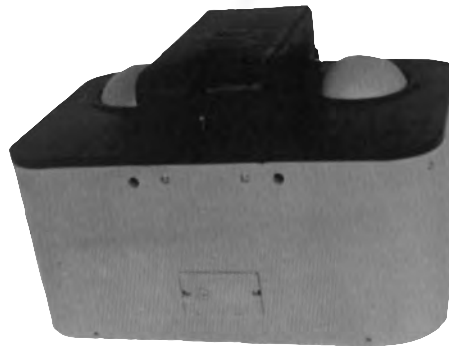

INSTALLATION INSTRUCTIONS AND SPECIFICATIONS FOR MODEL 3390E

READ CAREFULLY

MIRACO

A DIVISION OF
AHRENS AGRICULTURAL INDUSTRIES, INC.

BOX 686

GRINNELL, IOWA 50112

PHONE 641-236-5822

TOLL FREE 1-800-541-7866

FAX 1-641-236-3341

website: www.miraco.com

SPECIFICATIONS

PART 1 - GENERAL

A. DESCRIPTION:

1. The E-found is the finest operating, lowest cost, energy efficient livestock waterer on the market today. The sealed atmosphere helps prevent the formation of scum and algae. It also prevents tongue injuries from contact with frigid steel.
2. All edges are curved and sloped to prevent injury to people and animals.

B. WEIGHTS & DIMENSIONS

Model #	Capacity	Gallons	Description	Dimensions	Weight
3390-E	150 hd. beef	40	2-10 3/4" ball closures	43" x 29" x 20"	119 #
	60 hd. dairy		10" opening		
	20 horses		Removable ends		

C. MATERIAL NECESSARY FOR INSTALLATION:

1. Concrete
2. P.V.C. Glue
3. #834 insulated tube
4. Thread sealer or teflon tape



PART II - MATERIALS, PRODUCTS

A. MATERIALS:

1. High impact Rockite™ polyethylene.

B. INSULATION:

1. The base, cover and lid closures are filled with a 3" thickness of Urethane foam.

C. VALVE:

1. Miraco valve with brass rods and ends.

D. ELECTRICAL:

1. Cartridge heater – 75 watt
2. Cartridge thermostat

E FOUNT #3390E INSTALLATION INSTRUCTIONS

NOTE: For cold climates, insulate the upper portion of your heat well with styrofoam or blue board rigid insulation.



Step 1

Install your heat well at least 1' below frost or down to your water line to insure frost free operation. Install the water line so it comes up close to the center of the heat well. For existing installation where a small hole is all you have, use a low wattage heat tape on the line to prevent freezing.

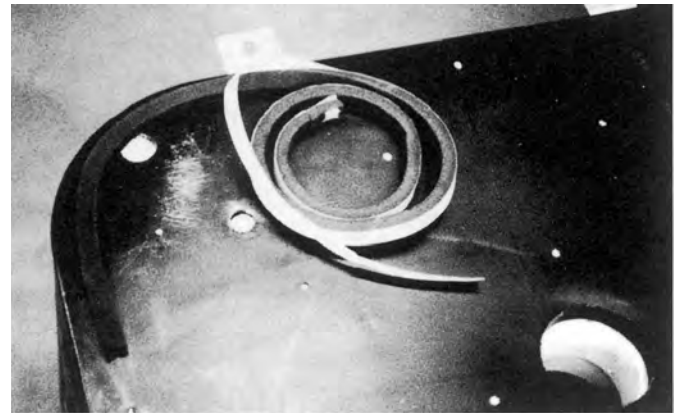

Step 2

Pull the paper backing off the rubber gasket furnished in your parts carton. Stick this gasket on the bottom of your tank. Keep the gasket as close to the edge as possible. This is necessary to keep air out and keep your heat well dry.

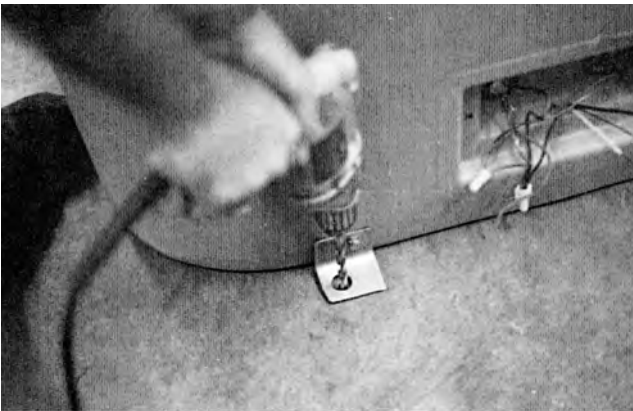

Step 3

After pulling your #14-3 romex or #14-2 with ground up through the hole provided, center your tank and drill 3/8" holes in the cement and drive the 3/8" stainless steel concrete anchors provided.

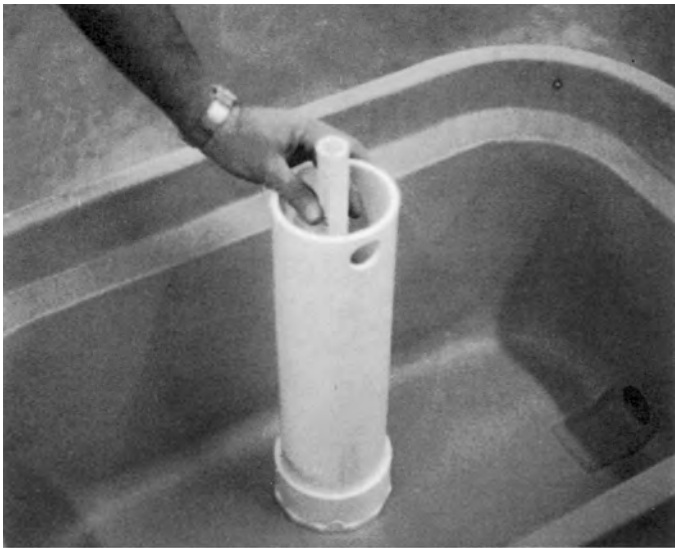

Step 4

After you have completed steps 1 thru 3, your fill line will be standing above the 4" riser pipe. Make sure the 4" pipe is pushed completely down into the bottom fitting.

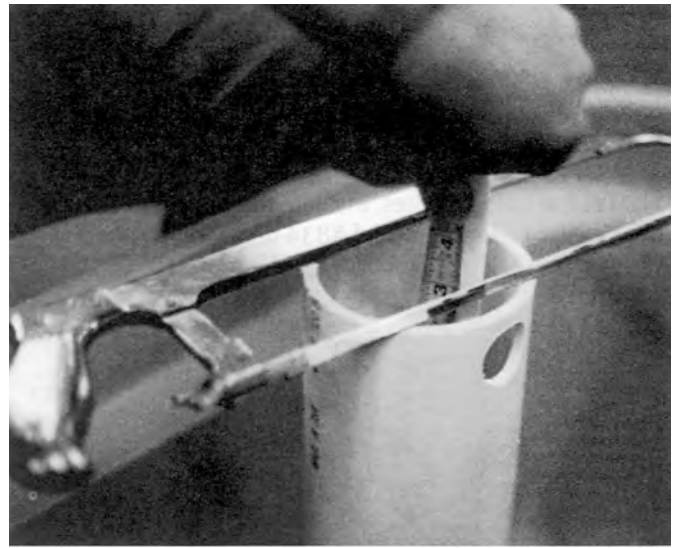

Step 5

With a pen or pencil, make a mark on the fill line 2 3/4" below the top of the 4" outer pipe.

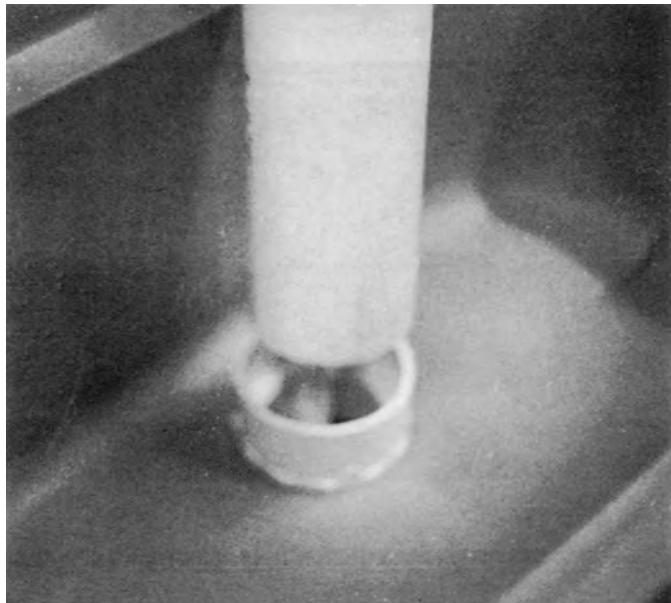

Step 6

The riser pipe is not glued into the bottom fitting. Pull the riser pipe out of the bottom fitting.

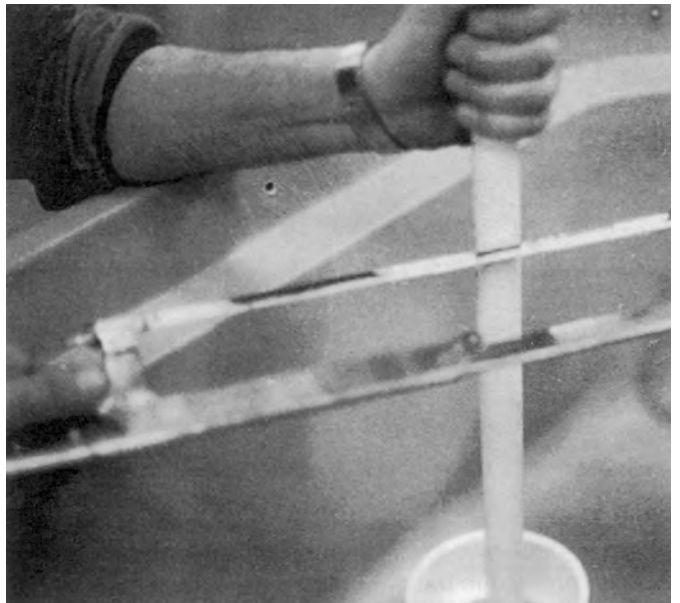

Step 7

With a hack saw, cut off the fill line where you made your mark previously.



Step 8

The pipe insulation should be up into the tank about 2". If you are using a low wattage heat tape to protect the water line, do not use the pipe insulation.

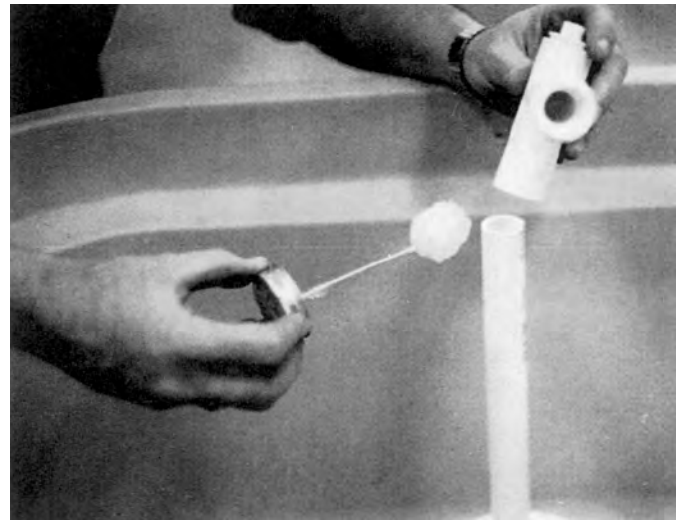

Step 9

After applying thread sealer on the plug in the 3/4" "T," glue the "T" assembly to the fill line with the threaded fitting pointed at the opposite wall of the tank farthest away from the line.



Step 10

Make any adjustments before the cement sets up.



Step 11

Using the same PVC cement, apply it to the bottom of your 4" riser pipe. Make sure all connections are clean before applying glue.



Step 12

After PVC cement has been applied, push the riser pipe into the bottom fitting and align with the "T" fitting so the "T" fitting fits into the 1 1/4" hold at the top of the riser pipe. Push the 4" pipe down completely to the bottom of the fitting.

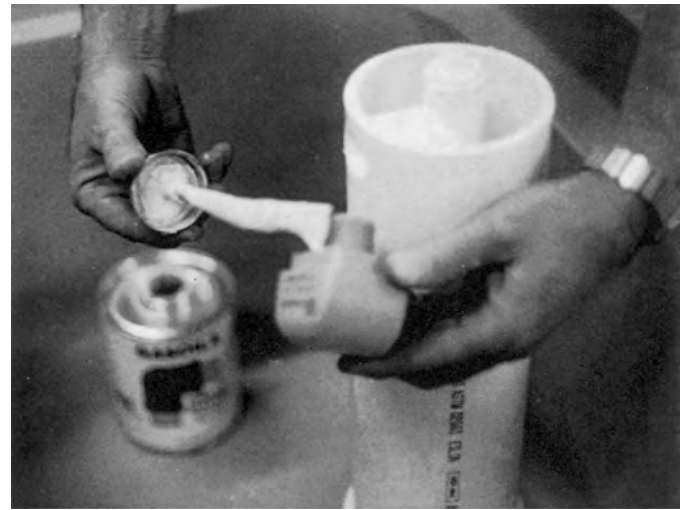

Step 13

Apply plumbers pipe cement to the valve threads or use teflon thread sealer.



Step 14

Screw the valve into the "T" fitting so the valve is tight. In most cases, hand tight is sufficient. If wrenches are required, be careful not to over tighten. Valve should be straight up and down when tightened. Valve should be back tight against the 4" riser pipe.



Step 15

Install the bob float and arm with the brass thumb screw. When the water level is at the proper setting, the horizontal arm should be parallel with the water and the vertical arm should be screwed up until the bob float is within 3/8" of the nylon fitting.

**Step 16**

All water adjustment can be done by turning the vertical arm up or down thru the top access.

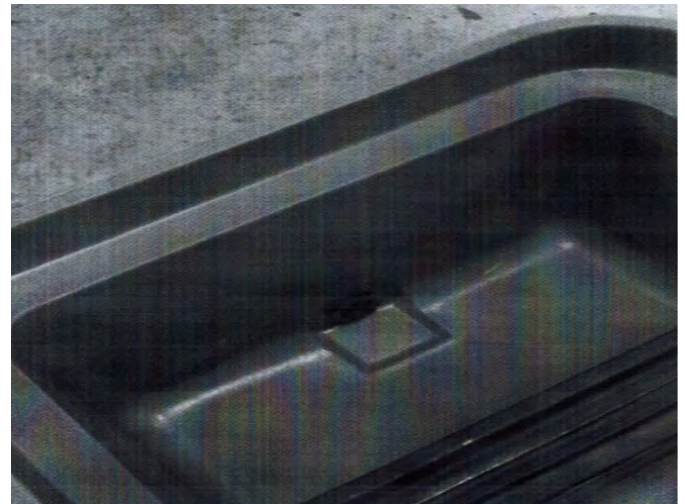
**Step 17**

Always place the drain plugs in from the inside to prevent them from coming out.

Miraco Livestock waterers Express warranty and Waiver of implied warranties and consequential damages

Express Warranty

Ahrens Agricultural Industries Co. , dba Miraco, expressly warrants that the Miraco waterers (excluding valve and valve parts) will be free of defects in materials and workmanship for a period of five (5) years from delivery. The Miraco valve and valve parts are warranted to be free of defects in materials and workmanship for a period of one (1) year from delivery. Such warranty does not apply to any Miraco unit that has been subjected to misuse, or material failure to install, operate or maintain in accordance with Miraco's written instructions, or other events acts or omission, including but not limited to acts of nature, which affect the Miraco unit materially and adversely and are not attributable to Miraco.

This warranty is limited to the repair or replacement of the defective part, at the option of Miraco. Such repair or replacement part is warranted only for the unexpired portion of the original warranty period. Buyers with warranty claims should contact their local dealer immediately.

Heaters in all electrically heated units are warranted for a period of one (1) year.

Waiver of implied warranties and Consequential damages

Except for the above express warranty, this product is sold as is. Implied warranties of merchantability and fitness for a particular purpose, as well as special, indirect or consequential damages, are all waived by the buyer.

NEW INSTALLATION METHOD

RIGHT

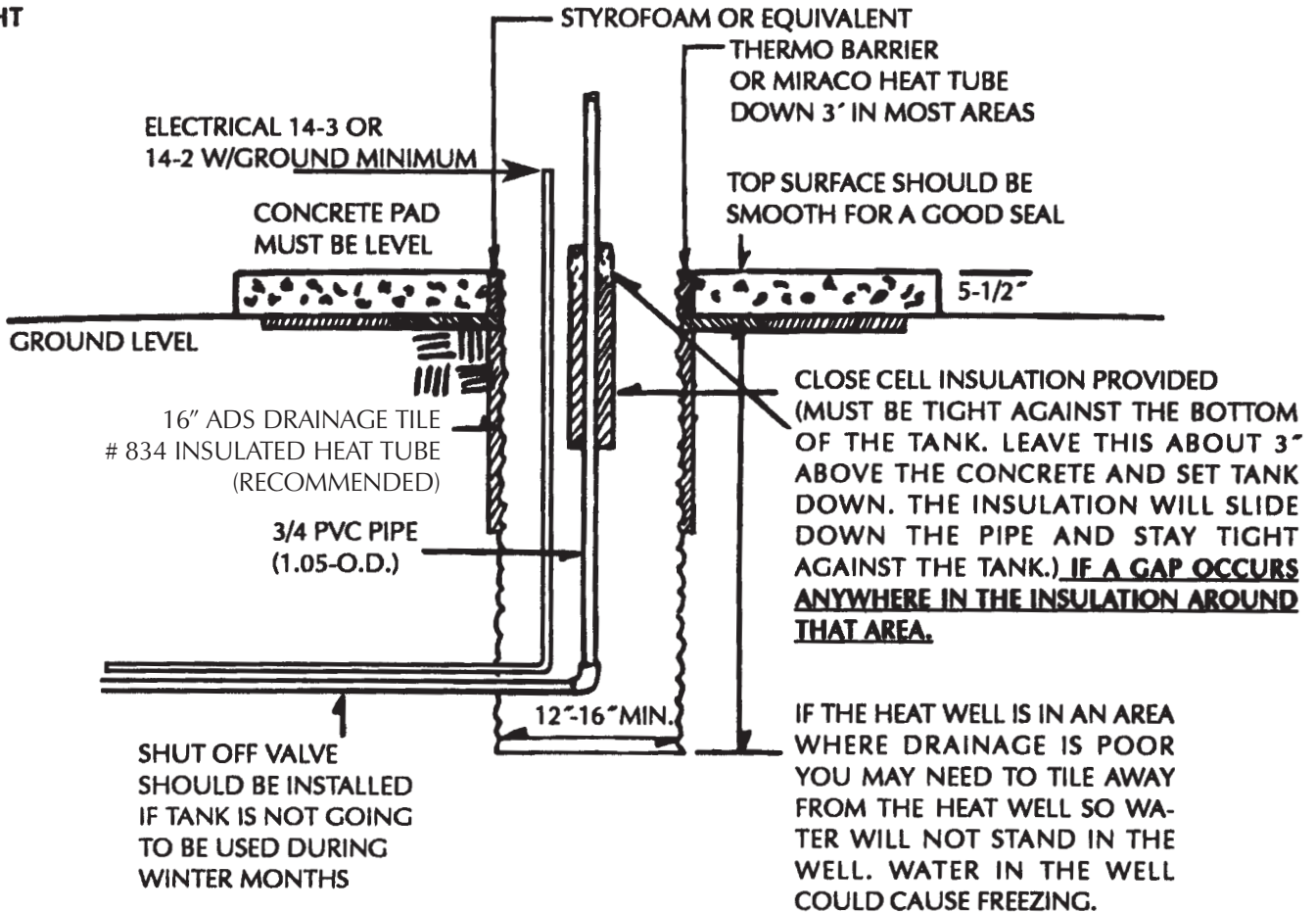

BASE AND ANCHOR PLATE DIMENSIONS MODEL #3390E

DRILL ANCHOR BOLTS IN AFTER SETTING TANK. USE $\frac{3}{8}$ " CEMENT DRILL

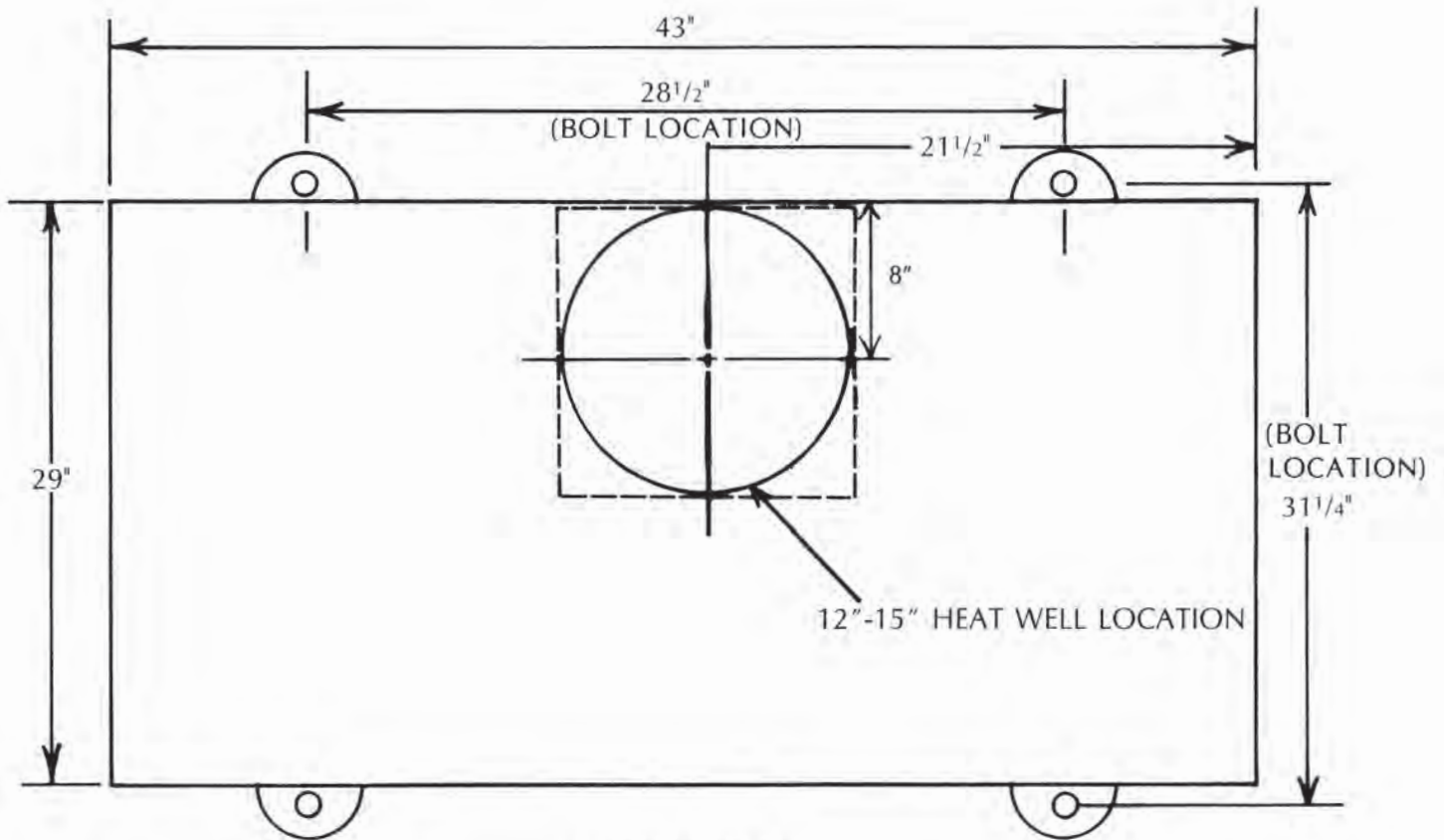

MODEL #3390E

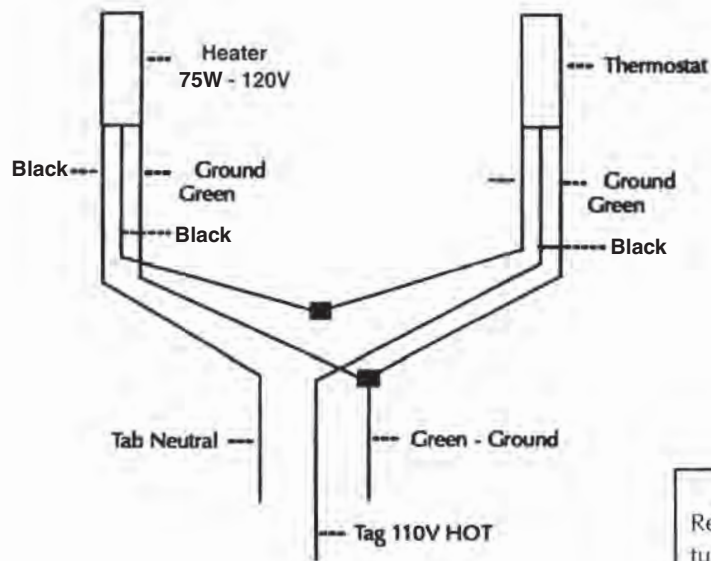

CAUTION
Read instructions carefully and turn electricity off at main fuse box before beginning installation.

FIELD CONNECTIONS

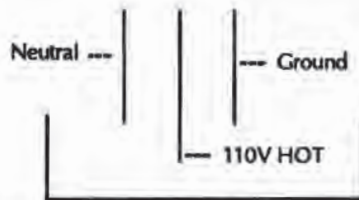

ELECTRICAL CONNECTION—Electrical service must be made and maintained by a qualified electrician. Each fountain must be wired through a fuse box with proper sized wire. (Refer to access plate for electrical requirements.) Hot wire must be run through the thermostat, and the neutral wire run to the white wire or neutral marked wire in junction box. A copper ground rod, buried in a minimum of 10' in soil, must be provided at each fountain. Connect ground wire from rod to ground connection in junction box.

THERMOSTAT—Preset at the factory for 50°.

WARNING—NEVER ALLOW THE E-FOUNT TO SET EMPTY UNLESS THE HEATER HAS BEEN TURNED OFF. ALWAYS DISCONNECT ELECTRICITY TO THE E-FONT BEFORE DRAINING. DAMAGE TO THE TANK CAN OCCUR.

WARNING: THIS INSTALLATION MUST BE MADE AND MAINTAINED IN STRICT CONFORMITY WITH NATIONAL/LOCAL PLUMBING CODES AND NATIONAL/LOCAL ELECTRICAL CODES (CSA IN CANADA). THE APPLICABLE PROVISIONS OF THESE CODES TAKE PRECEDENT. FAILURE TO MAKE AND MAINTAIN ALL INSTALLATIONS PROPERLY MAY RESULT IN LOSS OF LIVESTOCK, PERSONAL INJURY, OR DEATH.

NOTICE: CANADIAN ELECTRICAL CODE—PART 1 REQUIRES LIVESTOCK WATERERS INSTALLED IN FEEDLOTS IN OPEN FEEDING AREAS SHALL BE GROUNDED BY A SEPARATE COPPER GROUNDING CONDUCTOR OR AT LEAST NO.6 AWG TERMINATING AT A POINT WHERE THE BRANCH CIRCUIT RECEIVES ITS SUPPLY.

MODEL #3390E

MANAGEMENT TIPS FOR THE E-FOUNT

1. A 1/4" bolt is to be used to hold the balls back for training livestock. The 1/4" bolt is inserted into a threaded insert in the baffled portion of the lid. This holds the balls back for training.
2. Water level is very important. If the water is too high, the balls will stick shut in the winter time and the tank will appear frozen. A kick or a small amount of hot water on the balls will fix the problem. Then lower the water level so this won't happen again. However, never lower the water below the baffle, or cold air could go under and freeze your valve.
3. In case of power failure, merely keep the livestock away from the waterer so they can't drink it down. If this has already happened, then a small amount of hot water is all you need. **NEVER USE AN OPEN FLAME TO THAW ICE!**
4. Management is necessary in any operation and this includes checking your waterer daily. Water is very important and any malfunction should be attended to immediately. This is good practice for any make of waterers.
5. E-founts must be installed level, otherwise one ball will be higher than the others.
6. E-founts should be cleaned periodically, especially the ones being used for hogs. Mud can hamper the proper operation of the E-founts since the balls have to move freely in order to have proper operation.
7. If your valve is seeping, check the valve for foreign materials first. This is the biggest cause of seeping valves. If you have extremely rusty water or dirty water, your valve should be cleaned periodically.
8. If you have any questions give us a call at 641-236-5822.
9. If valve persists on leaking, use an allen wrench to tighten the orifice under the plunger. Turn clockwise to tighten.
10. Drain plugs are to be placed inside the tank to plug the drain hole.
11. Never allow your E-founts to empty with the heat elements on. This could lead to damage to the element, tank or both. If you are going to drain your tank for any length of time, be sure your power is turned off.
12. Temporary Emergency Measure: If the thermostat fails during freezing weather, water can be kept ice free by wiring direct. 1) Disconnect electric power to the waterer. 2) Remove wire nuts from the two thermostat connections; do not break connections. 3) Place two bare wire connections together and connect with the wire nut. 4) Replace thermostat as soon as possible. 5) Turn power back on, the heater will run continuously.
13. Electric Heaters: The tubular heaters have an incoloy sheath which is superior to stainless steel which is resistant to corrosion. However, the heater should be brushed clean periodically to prevent lime and scale buildup. This will let the heater work more efficiently and extend its life.