

Installation Instructions for



Thrifty King CT Series Fountains

Congratulations, you have just purchased the finest watering fountain on the market. This unit is built to give you excellent service when properly installed and maintained. Please follow instructions carefully. Read and understand all instructions before installing

Models CT1-2000, CT2-2000, CT4-2000, & CT6 Fountain Installation Instructions

Thrifty King fountains are intended to be energy free, however, a number of factors must be met for this to be the case:

- There must be at least 10 animals that have the Thrifty King fountain as their only source of water.
- There must be a good seal against wind between the concrete platform and base of the unit.
- The water seal grooves between the base, and top of the unit, and between the top of the unit and the valve cover must be filled with liquid.
- The supply water temperature must be at least 42°F. (This may be an issue for rural or municipal water supplies.)

If these factors are not met, supplemental heat is recommended. Please see Supplemental Heat in the Special Situations section of this manual, page 5 for specific recommendations.

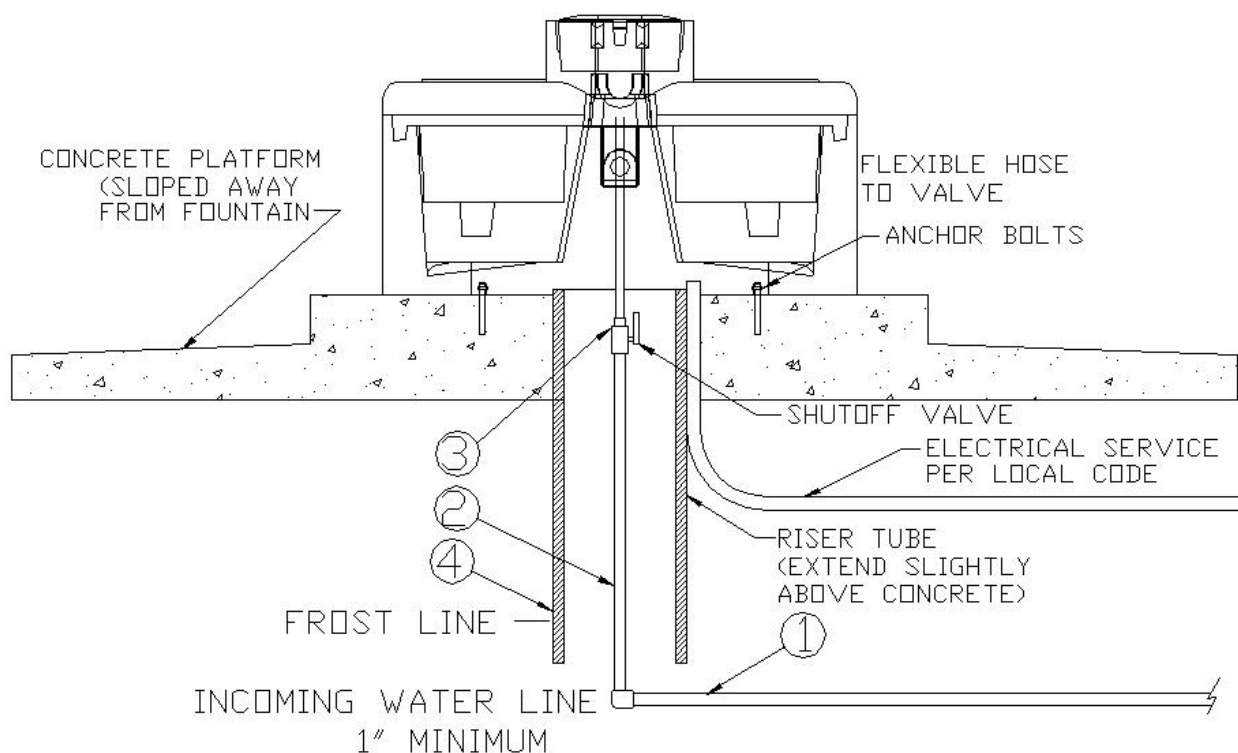

A. **Location** - Putting the fountain in a location that offers protection from the wind will enhance the performance of the fountain. Livestock will tend to gather in this protected area, enticing them to drink more. If possible, the side that supply line enters the fountain should be opposite of prevailing winter wind to give additional protection to the supply line.

B. **Water Supply Line** - The horizontal underground water line (#1) should be sized to account for pressure drop, relating to distance, at least 3/4" in diameter (1" recommended) and 1' below normal frost depth. A 3/4" (1" recommended) vertical supply pipe (#2) is recommended for Thrifty King units. A shut-off valve (#3) may be installed under the fountain for easier servicing. For optimum serviceability a stop and waste valve can be installed below frost level to drain water back when unit is not in use. Flush water supply line thoroughly before connecting to fountain.

C. **Riser Tube** - Install a riser tube (#4) around pipe to provide room for plumbing and to accommodate optional shut-off valve. Ensure that the water supply line is centered in the riser tube. Do not add any insulation in the riser tube, as it provides a path for frost. For optimum water line protection, use the 12" outside diameter insulated Ritchie Thermal Tube. Use whatever combination of Thermal Tubes is required to reach at least 1' below frost line.

Ritchie Thermal Tube	
Part #	Description
18158	1' Top Section
16417	2' Top Section
16612	4' Top Section
16416	2' Extension

NOTE: The supply line touching the riser tube is the most common cause of the supply line freezing. Do not surround the supply line with insulation, wood, or other foreign material. Use only the foam hose insulation provided around the supply line. Any foreign material in the tube may cause frost to migrate to the supply line causing it to freeze.

D. **Electrical Connection** (Optional) - Although Thrifty King fountains are designed to be electric free, there are circumstances where supplemental heat (see page 4) may be required. If electricity is available, it is a good management decision to run the electrical line for future use in the event your operation changes and no longer meets the requirements for electric free. The electrical installation should be made and maintained by qualified electrician conforming to national and local codes.

E. **Mounting Platform** - A concrete platform should be provided for all fountains. It should be at least 4" thick, 6" recommended thickness, and large enough to accommodate the fountain. An additional 4" high step 18" out from each side of the unit will protect the unit from manure handling equipment, as well as discouraging animals from defecating in the fountain. Extending the platform provides animals a place to stand while drinking, consider the size of your animals when determining the dimensions of your platform. Slope the platform away from the fountain for drainage. A rough broom finish on the concrete surface provides better footing for animals.

F. **Preparing the Bottom** - Apply the foam weather stripping to the bottom of the unit, around the outside edge of the fountain. Use additional foam weather stripping provided to create a seal between the outside edge of the riser tube and access opening on the bottom of the fountain. Apply foam around the opening in the base. You may choose to apply a double layer of foam since it is recessed relative to where you applied the foam around the outside edge of the fountain.

G. **Hold-Downs** - Thrifty King Fountains have mounting pockets molded into the base. Use of Ritchie stainless steel anchor bolts (not included) is recommended for concrete installations. Anchor bolts are available from Ritchie in packages of two, part #16555.

H. **Position Fountain** - Connect hose to the top of the supply line, or the customer supplied shutoff valve at the top of the concrete. Slide foam rubber hose insulation down over the hose. Place fountain on the concrete platform over the riser tube so the supply hose is centered in riser tube. Bring the supply hose up through the access opening in bottom of fountain - cut the hose to the length required to connect to the valve. **NOTE:** Unit should be level to insure proper operation.

I. **Hose Connection** - Slip the end of the hose onto the barb fitting of the valve assembly. Clamps and fittings are furnished to secure the connection. Slide hose insulation up toward valve as far as possible, and fasten with nylon tie wrap. The insulation will cover part of the valve when properly positioned.

J. **Drain Plug** – The pre-assembled drain plugs should go on the lower holes on the side-wall of the unit. **Install drain plugs from inside of trough.** Wetting the plug can aid in proper installation. **NOTE:** To drain the unit, you can push the plug from outside of the unit in to the center of the unit, instead of reaching into the water to pull the plug out. After the fountain drains, then reach in to retrieve the plug and install it from the inside.

K. **Seal the Base** - After the unit is completely installed, apply a bead of caulking around the base of the fountain to ensure no wind enters through the base of the unit. **NOTE: sealing the bottom of the unit from cold air is an important aspect of the unit's thermal performance.**

L. **Install Unit Top** - Set the elliptical closures inside the unit base. Place the top of the fountain on the base and position the elliptical closures to sit in the drink wells. (Final placement will require the closures to float in the well.) Thrifty King fountains employ the water seal design. Fill the water seal groove with liquid to seal against air infiltration before assembling. Bolt the unit top down to the base using the bolts, washers, and nuts provided.

Tip: You may use vegetable oil to fill the water seal groove, or coat the inside of the groove with baking pan coating spray before filling with water to make the cover easier to remove and reinstall during freezing weather. For areas with high evaporation, using vegetable oil may be necessary.

M. **Float Adjustment** - Turn on water supply, check for and correct any leaks, and adjust float levels. For Thrifty King fountains, the water level should be adjusted to leave a gap of 1/2” between the elliptical closure and the rim of the water well. If the closure rests against the rim, they are more likely to freeze together.

N. **Install Valve Chamber Cover** - Again fill the water seal groove with liquid to seal against air infiltration before assembling. For the CT6, use the J-bolts provided to attach the valve chamber cover to the top. For all other units, drop in the valve chamber cover.

O. **Cleaning Your Fountain** – To clean your watering fountain you will need a good stiff bristled brush. Remove the cover then brush the water seal groove to remove any build-up then brush the tank. Remove the drain plug that is located at the end of the trough to drain out the water and debris. You can shut off the water with the shut-off valve located under the unit or by holding the float in the up position. After the water and debris has drained reinstall the plug and let the tank refill. Now is a good time to readjust the float if needed. Reinstall cover and you are done.

Thrifty King Product Specifications				
	CT1-2000	CT2-2000	CT4-2000	CT6
Drink Height	19	19	19	19
Width	20.25	24	35	39
Length	28	42.75	42.75	72.5
Shipping Weight	53 lbs.	90 lbs.	152 lbs.	210 lbs.
Operating Capacity	11.2 gallon	28 gallon	45.5gallon	55 gallon
Herd Capacity	30 Head	100 Head	200 Head	300 Head

Special Situations Supplemental Heat

Immersion heaters are available for cold weather climates. The 250-watt heater part #16311 should be adequate for Thrifty Kings. Additionally, self-regulating heat cables are available to protect supply hose from freezing, 120V, part #16276. Immersion heaters should be placed flat on the bottom of the valve chamber. Ensure that the placement of the heater and its power cable do not interfere with the motion of the float assembly.

Note: Supply line heat cables should wrap around the valve, and follow the supply line down into the riser tube. You may use nylon ties to anchor the heat cable to the supply line.

Non-Siphoning

The Ritchie Thrifty King fountains meet Grade-A dairy non-siphoning guidelines.

Ritchie Valves

Ritchie valves come in two sizes and four pressure ratings – blue for very high pressure, green for high supply line pressure, red for moderate supply pressure, and white for low-pressure applications. Differences in the size of trough also impacts valve choice. Although different pressure rated valves may be used in a fountain, each fountain will only accommodate one size and configuration of valve.

The Thrifty King CT1-2000 uses the smaller 1/2" valves. A white valve is standard on the CT1 units. This valve accommodates most common operating pressures, and provides more than adequate water flow rates for the number of animals that could be drinking at any one time from these troughs.

1/2"	Part #	GPM	Pressure Range
White	12574	4.8	Low, 5-40 psi
Red	12575	3.4	Moderate, 40-60 psi
Green	13597	1.45	High, 60-80 psi

3/4"	Part #	GPM	Pressure Range
White	16697	33	Low, 5-40 psi
Red	11101	20	Moderate, 40-60 psi
Green	15377	16.5	High, 60-80 psi
Blue	18198	5	Very High, 80-100 psi

The Thrifty King CT2-2000, CT4-2000 and CT6 use our larger 3/4" valves. Green valves are standard on the CT2-2000 and CT4-2000, and a red valve is standard on the CT6.

Alternate valves can be used for different water conditions. If water pressure is over 60 psi, and if the

valve does not shut off, a pressure-reducing valve may be needed.

Your individual situations may require a change from the standard valve supplied with your fountain, see your Ritchie Dealer if this is needed.

Thrifty King CT6

Part # 16440

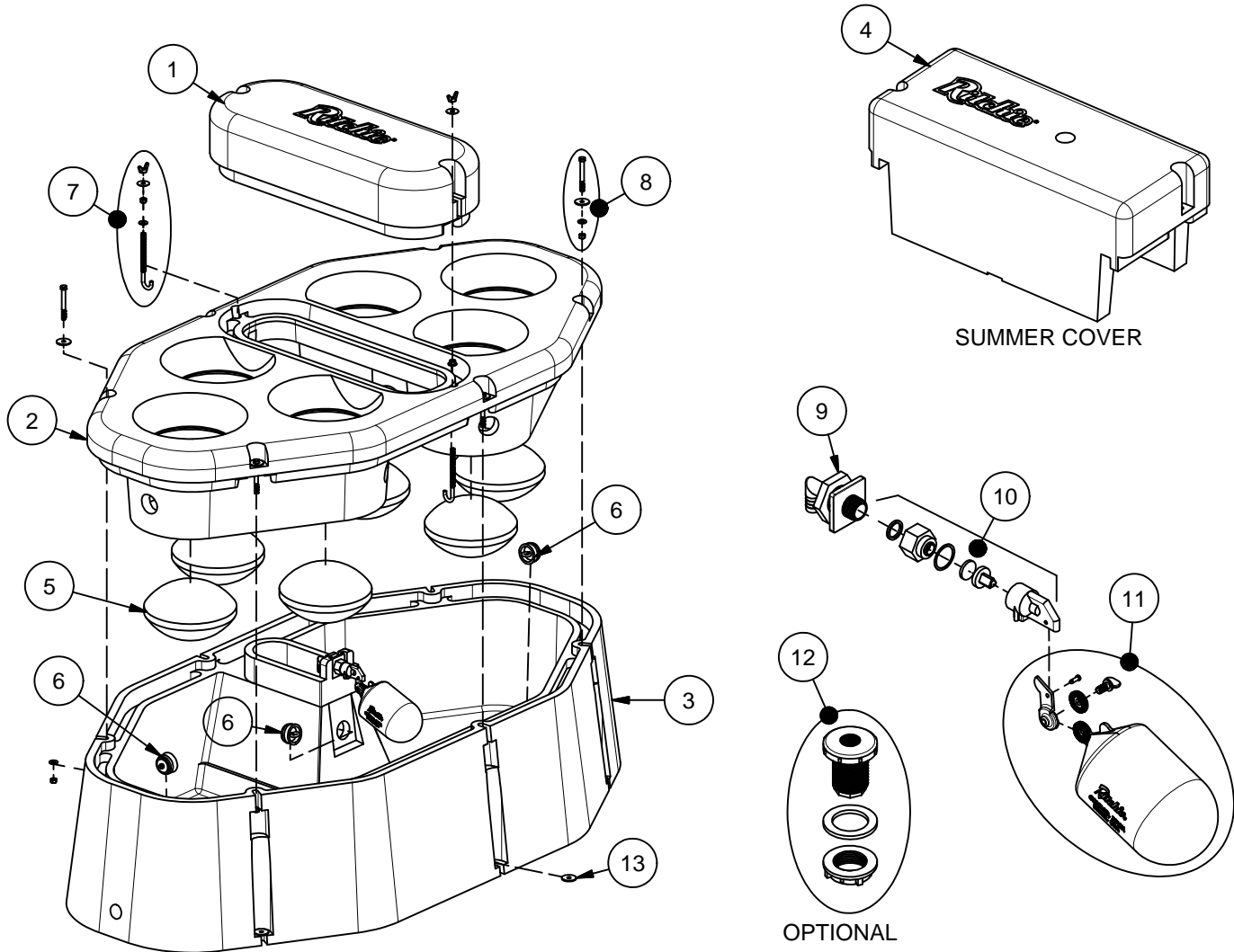

Item	Part #	Description	Qty	Item	Part #	Description	Qty
1	16391	Thrifty King CT6 Cover	1	11	18314	Float with Hardware pkg	1 pkg
2	16443	Thrifty King CT6 Top	1		18313	Hardware for Float pkg	1 pkg
3	16442	Thrifty King CT6 Base	1	12	18624	Optional Non-Potable Vlv Adptr	1 pkg
4	18090	Thrifty King CT Summer Cover	1	13	18318	Bolt Down Washer (4/pkg)	2 pkg
5	16305	Elliptical Closures	6	NS	14866	Seal Foam 10' Roll	2
6	18219	Drain Plug #11 pkg	3 pkg	NS	14859	Pipe Insulation	1
7	16540	J-Bolt CT6 SS (2/pkg)	1 pkg	NS	15931	Hose Clamp 1" SS (5/pkg)	1 pkg
8	16288	Top Bolt, Wshr, & Nut SS (2/pkg)	3 pkg	NS	18614	Adapter 3/4" x 5/8" HB	1 pkg
9	16422	Valve Bracket with Nut	1 pkg	NS	16441	TK CT6 Accessory pkg	1 pkg
10	12570	Red Valve 3/4" Female pkg	1 pkg	NS	16646	Opt. Ribbed Elliptical Closures	6

Thrifty King CT4-2000

Part # 16430

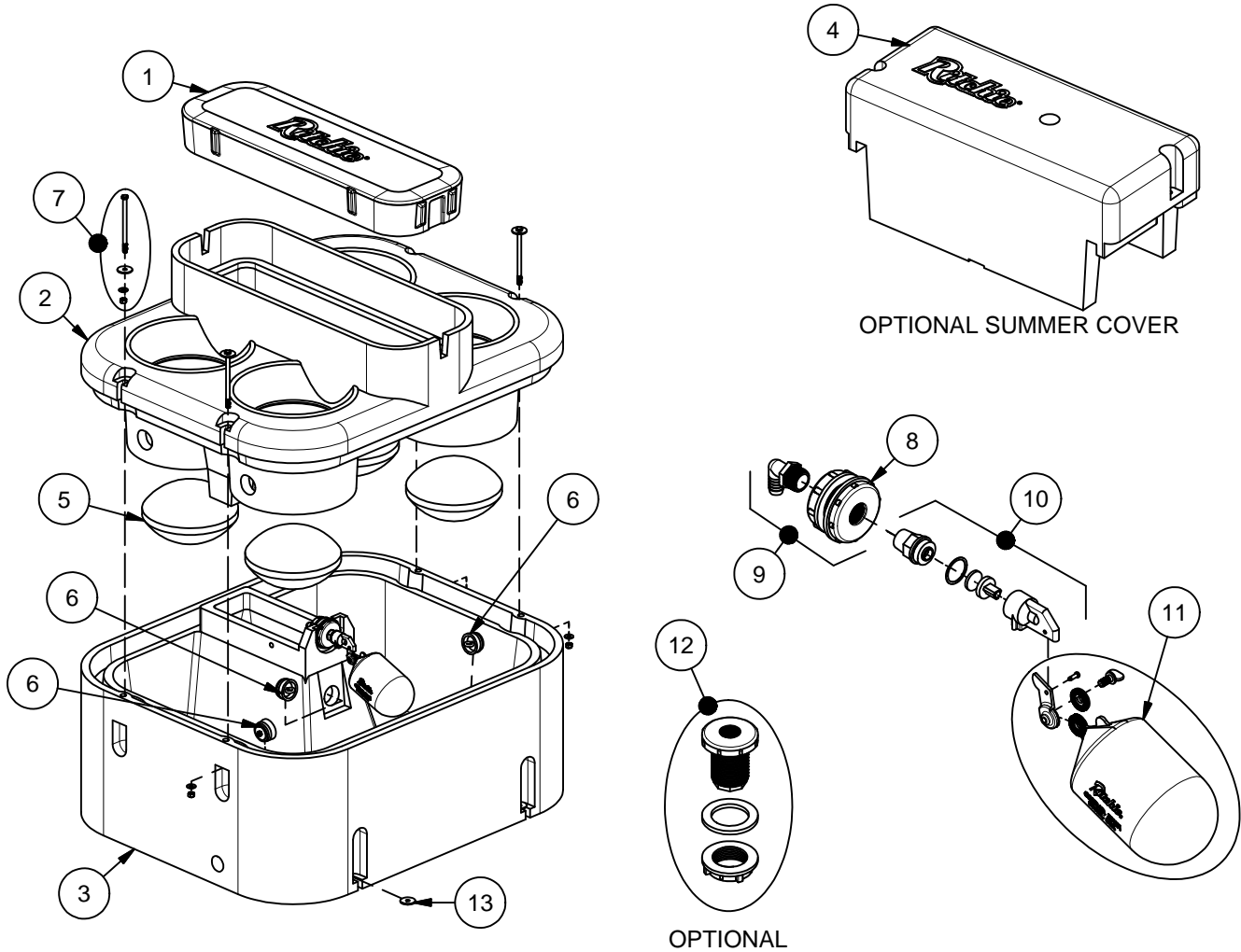

Item	Part #	Description	Qty	Item	Part #	Description	Qty
1	18121	Thrifty King CT4 Cover	1	11	18314	Float with Hardware pkg	1 pkg
2	18120	Thrifty King CT4 Top	1		18313	Hardware for Float pkg	1 pkg
3	18119	Thrifty King CT4 Base	1	12	18624	Optional Non-Potable Vlv Adptr	1 pkg
4	18090	Optional TK CT Summer Cover	1	13	18318	Bolt Down Washer (4/pkg)	1 pkg
5	16305	Elliptical Closures	4	NS	14866	Seal Foam 10' Roll	2
6	18219	Drain Plug #11 pkg	3 pkg	NS	14859	Pipe Insulation	1
7	16538	Top Bolt, Wshr, & Nut (2/pkg)	2 pkg	NS	15931	Hose Clamp 1" SS (5/pkg)	1 pkg
8	18625	Bulkhead Fitting 3/4" NPT	1 pkg	NS	18614	Adapter 3/4" x 5/8" HB	1 pkg
9	16898	Bulkhead with Elbow	1 pkg	NS	18155	TK CT 4 Accessory pkg	1 pkg
10	15377	Green Valve 3/4" Male pkg	1 pkg	NS	16646	Opt. Ribbed Elliptical Closures	4

Thrifty King CT2-2000

Part # 16299

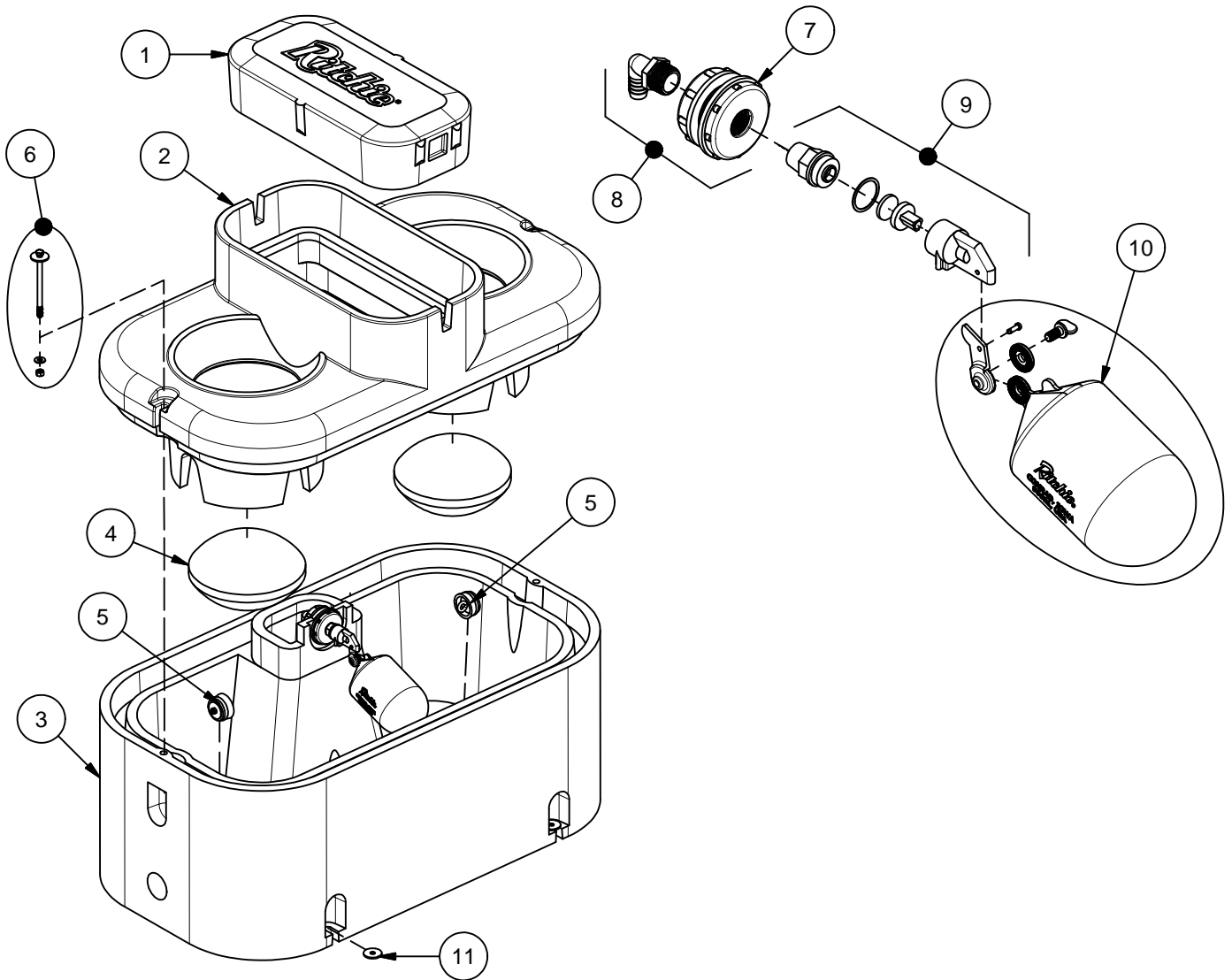

Item	Part #	Description	Qty	Item	Part #	Description	Qty
1	16893	Thrifty King CT2 Cover	1	10	18314	Float with Hardware pkg	1 pkg
2	16894	Thrifty King CT2 Top	1		18313	Hardware for Float pkg	1 pkg
3	16895	Thrifty King CT2 Base	1	11	18318	Bolt Down Washer (4/pkg)	1 pkg
4	16305	Elliptical Closures	2	NS	14866	Seal Foam 10' Roll	2
5	18219	Drain Plug #11 pkg	2 pkg	NS	14859	Pipe Insulation	1
6	16538	Top Bolt, Wshr, & Nut (2/pkg)	1 pkg	NS	15931	Hose Clamp 1" SS (5/pkg)	1 pkg
7	17461	Bulkhead Fitting 3/4" NPT	1 pkg	NS	18614	Adapter 3/4" x 5/8" HB	1 pkg
8	16898	Bulkhead with Elbow	1 pkg	NS	18340	TK CT2 Accessory pkg	1 pkg
9	15377	Green Valve 3/4" Male pkg	1 pkg	NS	16646	Opt. Ribbed Elliptical Closures	2

Thrifty King CT1-2000

Part # 16271

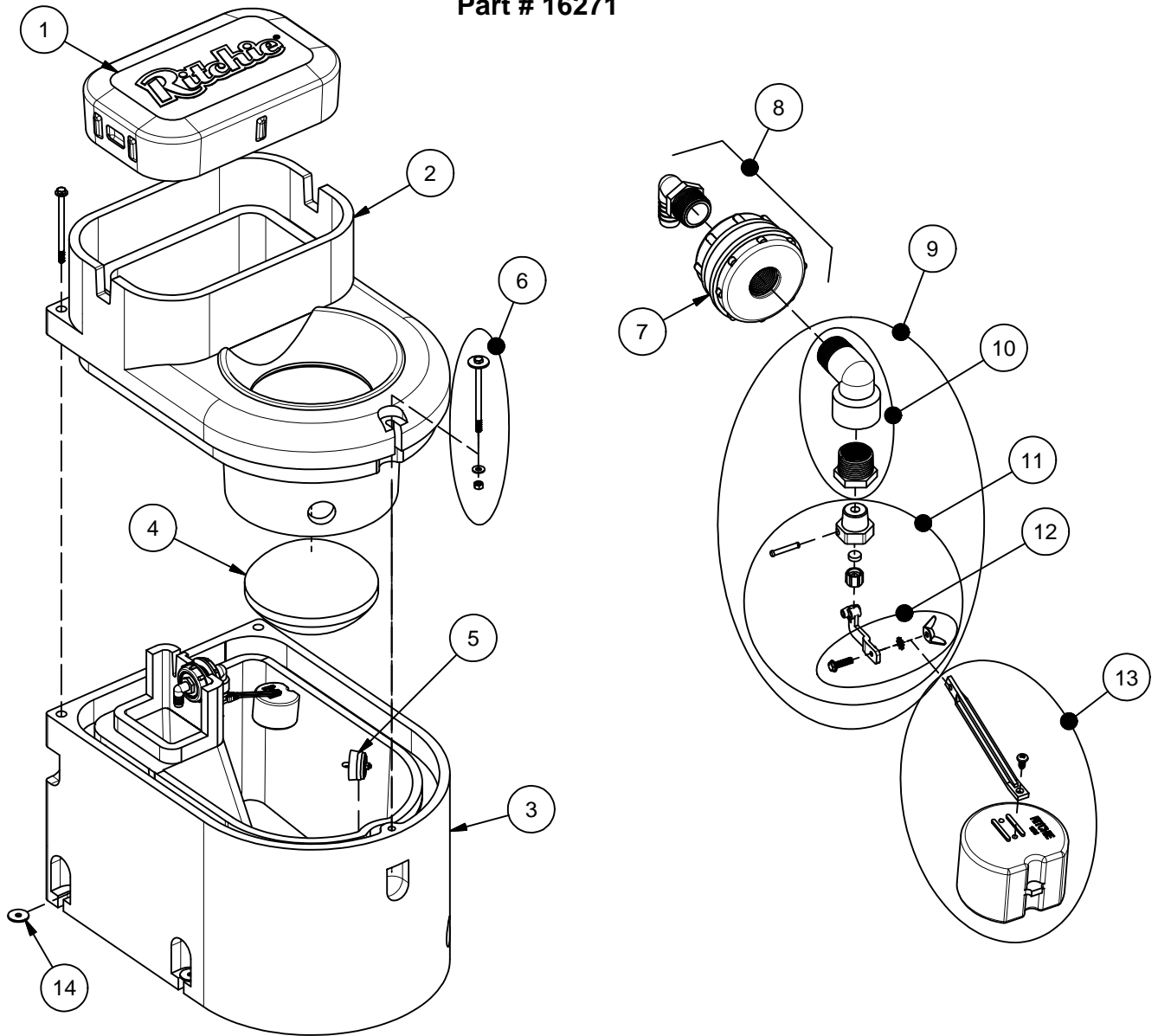

Item	Part #	Description	Qty	Item	Part #	Description	Qty
1	16861	Thrifty King CT1 Cover	1	10	16287	Adptr Reducer 3/4" to 1/2" pkg	1 pkg
2	16860	Thrifty King CT1 Top	1	11	12574	White Valve 1/2" Male pkg	1 pkg
3	16859	Thrifty King CT1 Base	1	12	12576	Wingnut/Screw Assembly	1 pkg
4	16305	Elliptical Closures	1	13	12836	Float with Long Arm pkg	1 pkg
5	18219	Drain Plug #11 pkg	1 pkg	NS	14866	Seal Foam 10' Roll	1
6	16538	Top Bolt, Wshr, & Nut (2/pkg)	2 pkg	NS	14859	Pipe Insulation	1
7	18625	Bulkhead Fitting 3/4" NPT	1 pkg	NS	18614	Adapter 3/4" x 5/8" HB	1 pkg
8	16898	Bulkhead with Elbow	1 pkg	NS	16857	TK CT1 Accessory pkg	1 pkg
9	16899	White Valve 1/2" W/ Adpt pkg	1 pkg	NS	16646	Opt. Ribbed Elliptical Closures	1

Trouble Shooting

Problem	Solution
Elliptical Closure Sticking	Make sure the closure floats at least 1/2" below the rim of the water well, so water does not get trapped above the closure and freeze the closure to the rim of the well.
Water Freezing in the Valve, Supply Line, or Drink Area	Make sure the fountain is sealed from wind between the concrete platform and bottom of unit
	Make sure both water seal grooves are filled with liquid
	Make sure there are at least 10 animals drinking from only this fountain. (No other source of water available.)
	Make sure incoming water is at least 42°F
	Make sure supply line is properly insulated: <ul style="list-style-type: none"> ▪ Foam rubber insulation around supply line ▪ Riser tube with supply line centered, and air space between riser tube and supply line. Ritchie Thermal Tubes are recommended (see part listing page 2) ▪ Horizontal supply line is at least 1 foot below frost line
	If the above conditions cannot be met, use supplemental heat as described on page 4
Low Water Flow	Check that valve inlet is not plugged or supply hose is not kinked
	Check system pressure from supply hose by installing a tee and pressure gauge in front of the valve to check pressure drop when valve is open. A severe pressure drop indicates a restriction or undersized supply system.
	Check that shut off valves are fully open
Valve Won't Stop Dripping	Check float adjustment. Ensure float moves freely
	Take valve apart and check for sand or scale in valve rubber.
	Turn valve rubber over and re-assemble. See below
	Check for excessive water system pressure.
	Change to higher pressure valve.

1/2" Valve:

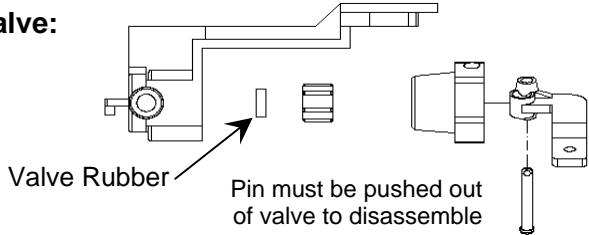

3/4" Valve:

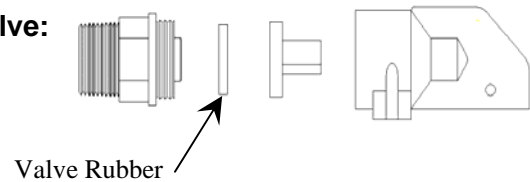

Ritchie Limited Warranty

Effective September 2012

Ritchie Industries, Inc. warrants its products to be free of defective materials and workmanship. Defective part(s) will be repaired or replaced at the option of Ritchie Industries. **This warranty specifically excludes all labor and shipping charges.**

This warranty does not apply to any appearance items, to any product whose exterior has been damaged or defaced, to any product that has been improperly installed, to any product subjected to misuse, abnormal service or handling, and to any products altered or repaired with other than original equipment or manufacturer's parts.

This warranty gives you specific legal rights, and you may also have other rights which vary from state to state.

All warranty claims must be processed through an Authorized Ritchie Dealer/Distributor. **Proof of purchase is required. This warranty is not transferable.** The period of warranty begins at original date of purchase as follows:

Poly Units

Base, top and ball closures

10 year limited against manufacturing defect. 100% first five years, then declining 20% per year for the remaining five years.

Stainless Steel Units

Stainless trough and stainless valve chamber frame:

Ten years against manufacturing defect or corrosion. 100% all ten years.

Casing and cover:

10 year limited against manufacturing defect. 100% first year, then declining 10% per year for the remaining nine years.

Component Parts

All component parts, such as floats, valves, heating elements:

One year from the date of purchase against manufacturing defect, 100%.

Hydrants

All component parts:

One year from the date of purchase against manufacturing defect, 100%.