

Installation Instructions for



OmniMaster 8

Congratulations, you have just purchased the finest watering fountain on the market. This unit is built to give you excellent service when properly installed and maintained. Please follow instructions carefully. Read and understand all instructions before installing.

Ritchie Industries, Inc.
800-747-0222
www.ritchiefount.com

Part # 24210
October 11, 2017



@RitchieWaterers

OmniMaster 8 Fountain Installation Instructions

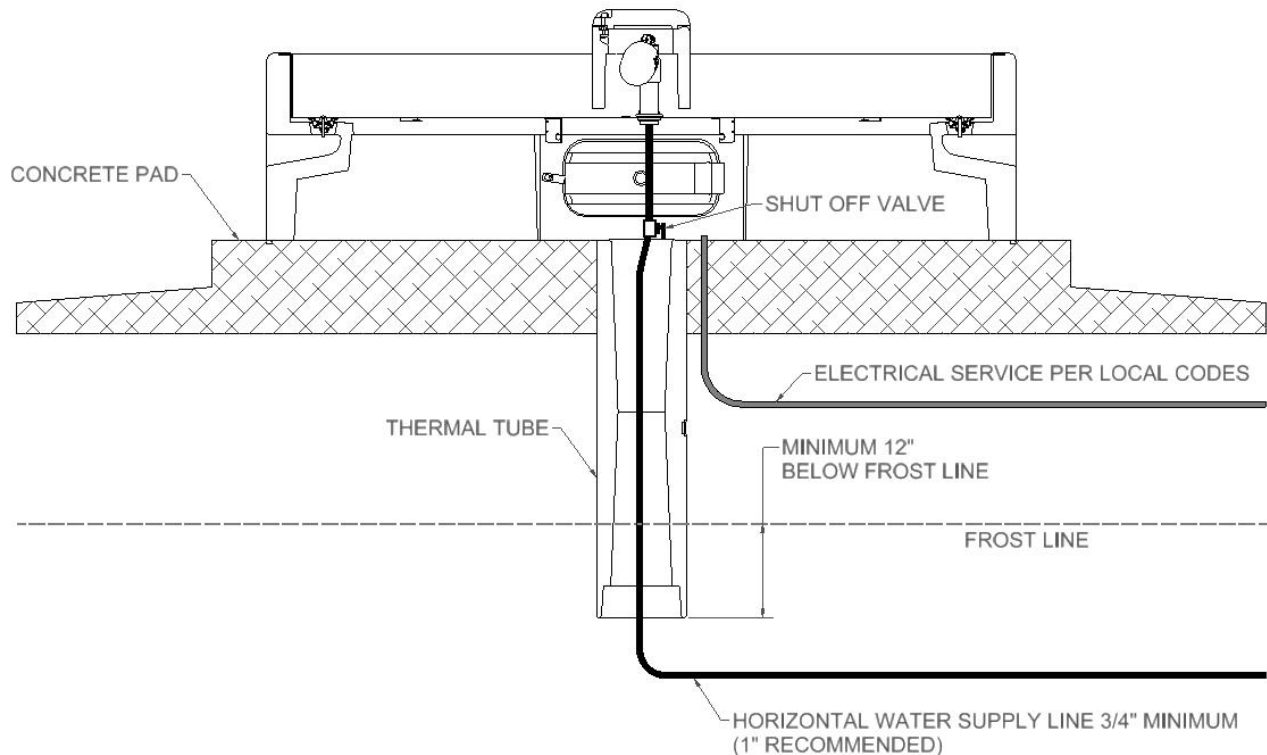

A. **Location** - Putting the fountain in a location that offers protection from the wind will enhance the performance of the fountain. Livestock will tend to gather in this protected area, enticing them to drink more. Access panel should be opposite of prevailing winter wind to give additional protection to the supply line.

B. **Water Supply Line** - Horizontal underground water line should be sized to account for pressure drop, relating to distance, and placed one foot below frost line. A one-inch vertical supply pipe is recommended. A shut-off valve should be installed under fountain to allow for easier servicing. For optimum serviceability, a stop and waste valve can be installed below frost level to drain water when unit is not in use. Vertical supply line must be centered in riser tube to provide an air space between the line and frozen ground outside of tube. Flush water supply line thoroughly before connection to fountain. Water supplies with foreign material such as sand, rust, etc. may require a filter to keep fountain valve working properly.

C. **Electric Supply** – It is generally most cost effective to run your electrical supply line at the same time you are trenching for your water supply.

WARNING: ANY ELECTRICAL SERVICE MUST BE INSTALLED AND MAINTAINED BY A QUALIFIED ELECTRICIAN PER LOCAL CODES.

D. **Riser Tube** - Install a riser tube and extend it at least one foot below frost line or down to horizontal underground water line. For optimum water line protection, use the 12” diameter insulated *Ritchie Thermal Tube*, part numbers and sizes are shown to the right. Tube opening must be kept clear.

Ritchie Thermal Tube	
Part #	Description
18158	1' Top Section
16417	2' Top Section
16612	4' Top Section
16416	2' Extension

NOTE: *The supply line touching the riser tube is the most common cause of the supply line freezing. Do not surround the supply line with insulation, wood, or other foreign material. Any foreign material in the tube may cause frost to migrate to the supply line causing it to freeze.*

E. **Mounting Platform** - A concrete platform must be provided for all fountains. Use a minimum of 4” thick, (6” recommended thickness), large enough to accommodate fountain, and additional 4” step (on top of the platform) extending 18” out from each side of the unit. This will protect the unit from manure handling equipment, as well as discouraging animals from defecating in the fountain. Extending the platform provides animals a place to stand while drinking, consider the size of your animals when determining the dimensions of your platform. The concrete step and platform should slope away from the fountain for drainage. A rough broom finish to concrete surface provides better footing for livestock.

F. **Anchoring Fountain** – OmniMaster 8 fountains have mounting pockets molded into the base: Use the pockets at each end when installing the unit flush against a wall. Use of Ritchie part #16555, stainless steel anchor bolts (not included), is recommended. Once you have verified the positioning of the fountain, drill, install, and tighten down anchor bolts. Use the large washers provided to hold unit down. Tighten hold down anchors tight, but do not over tighten as this could damage the plastic feet. Use an all-weather sealant under the outside edge when anchoring to concrete to keep air from leaking under fountain.

G. **Preparing the bottom** - Apply the provided foam weather stripping to the bottom of the unit, along the outside edge of the fountain.

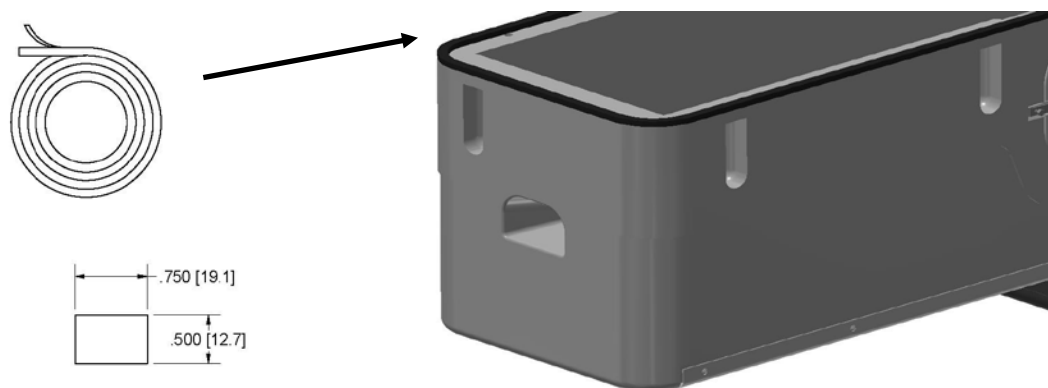

H. **Hose Connection** - Connect hose fitting to shut-off valve at top of concrete. Slip on barb fitting with furnished clamps. Hose should not touch insulation or outside surface of fountain. Place the hose under the fountain as you move the unit in place over the riser tube.

I. Valve Assembly for OmniMaster 8 –

1. Install standpipe into hole in trough. Rubber washer is to be on inside of trough. Tighten nut hand tight to allow for adjustment after valve assembly is installed.
2. Feed hose up through standpipe and attach to valve bracket. The hose may be shortened if necessary. Tighten the hose clamp securely to prevent leaks.
3. The lower front peg on valve bracket should be inserted into hole on standpipe first. Compress valve clip to snap in opposite hole on standpipe.
4. Remove pin from valve assembly.
5. Install float assembly on valve assembly using previously removed pin.
6. Rotate standpipe in trough until center of float aligns with center of trough. DO NOT allow float to be too close to cover when installed as this may hamper valve performance.
7. Tighten standpipe nut hand tight plus one-quarter turn. Use no joint compound for this fitting.

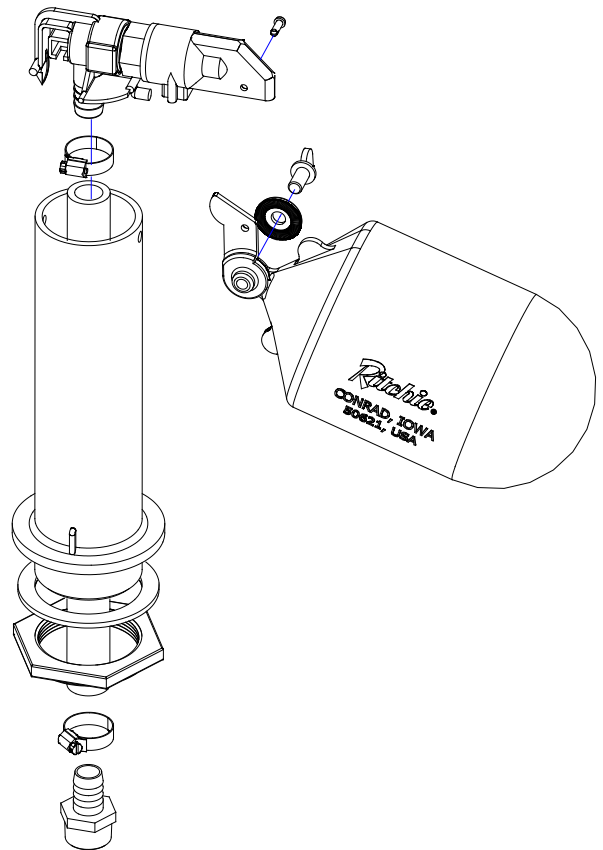

J. **Cable Heater** – Uncoil cable heater and loop around the valve. Attach the remaining part of the cable heater to the water supply, as far down the riser tube as possible with the cable twist ties provided. This heater is water tight, but should not be immersed in water. Heater may cross over itself, but should not be tightened at those locations.

CAUTION: Installation must not cause any strain on heater wiring connections. Avoid heater damage caused by hot spots due to its leads lying too close to each other. Also, do not wrap additional insulation around heater.

K. **Electrical Connection** - The electrical installation should be made and maintained by a qualified electrician conforming to national and local codes. A means for disconnection must be incorporated in the fixed wiring in accordance with the wiring rules. For wiring connections, see wiring diagram. Make connections according to the wiring diagram below.

WARNING: DISCONNECT POWER IF THE WATER SUPPLY IS TO BE SHUT OFF FOR AN EXTENDED AMOUNT OF TIME. FAILURE TO TURN OFF POWER CAN RESULT IN DAMAGE TO THE WATERING FOUNTAIN.

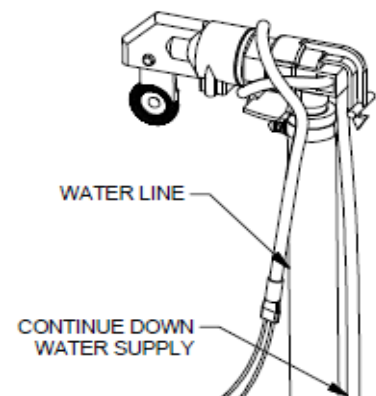

3/4" Valve Cable Heater Setup

WARNING: THIS INSTALLATION MUST BE MADE AND MAINTAINED IN STRICT CONFORMITY WITH NATIONAL/LOCAL PLUMBING CODES AND NATIONAL/LOCAL ELECTRICAL CODES (CSA IN CANADA). THE APPLICABLE PROVISIONS OF THESE CODES TAKE PRECEDENT. FAILURE TO MAKE AND MAINTAIN ALL INSTALLATIONS PROPERLY MAY RESULT IN LOSS OF LIVESTOCK, PERSONAL INJURY, OR DEATH.

NOTE: *National/Local electrical codes may require livestock waterers installed in feedlots in open feeding area to be grounded by a separate stranded copper grounding conductor or at least no.6 AWG terminating at a point where the branch circuit receives its supply. Check with local authorities.*

WIRING DIAGRAM 120V SINGLE PHASE

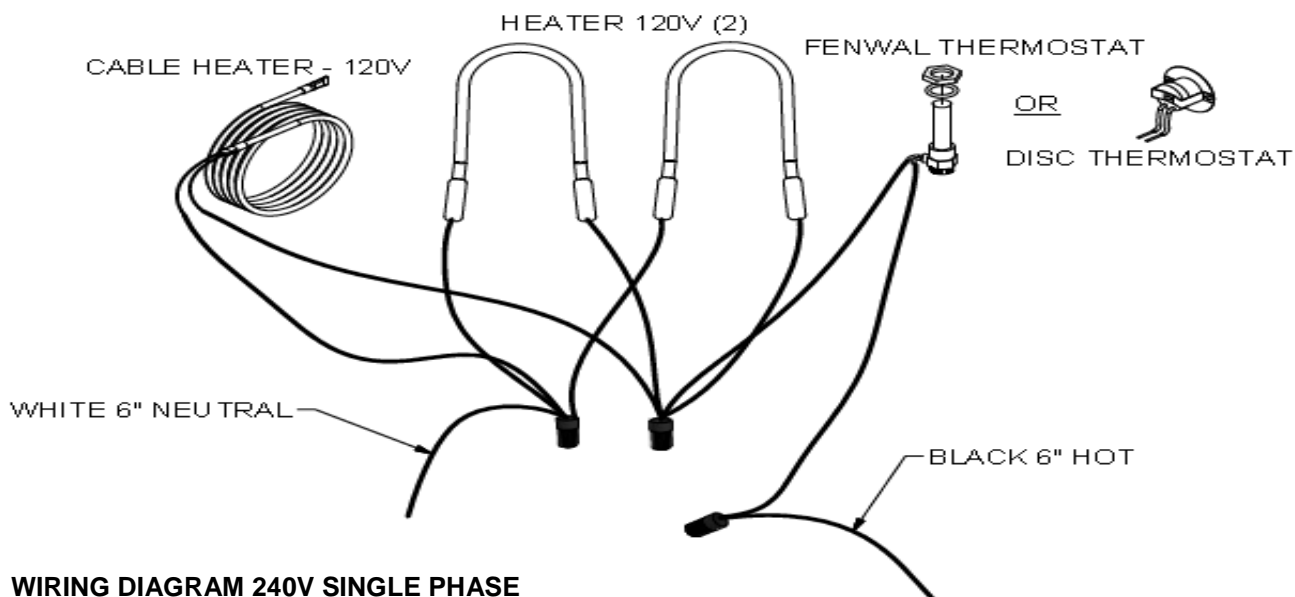

WIRING DIAGRAM 240V SINGLE PHASE

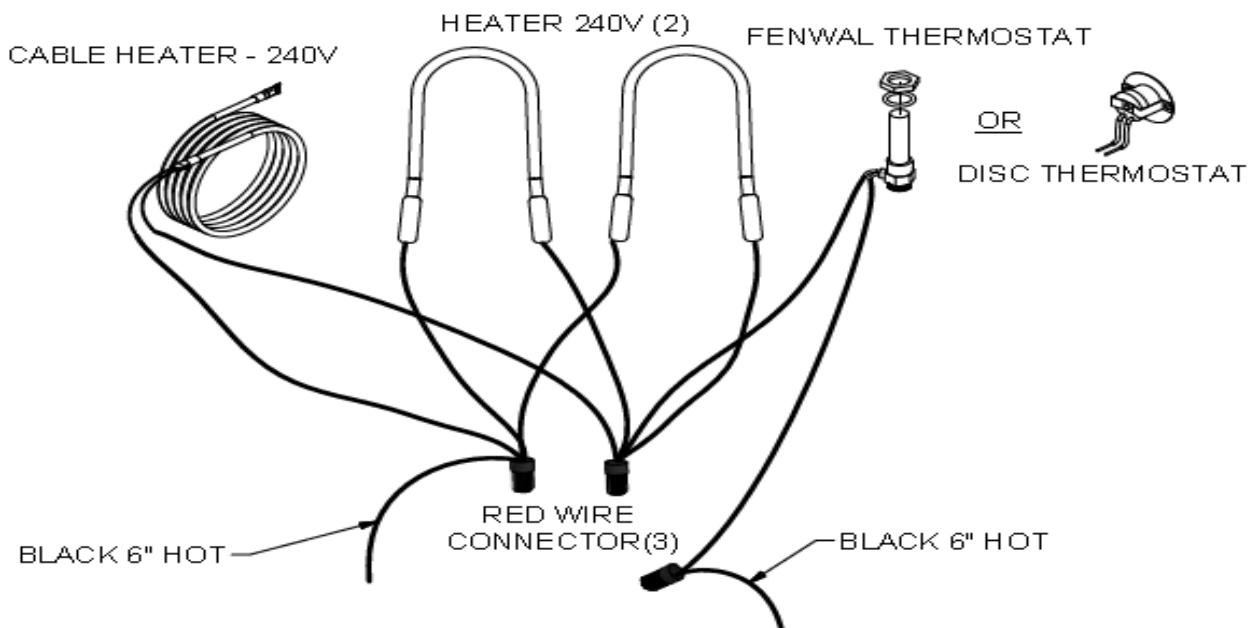

L. **Fenwal Thermostat** – The adjustable range is from 0° F (-18° C) to 100° F (38° C). Thermostat is not preset at factory. Fill the trough to proper water level. Check the water temperature with a thermometer. The next morning, check the water temperature again. If the water is warmer than desired, turn the thermostat down. If there is ice forming on the surface of the water, turn the thermostat up. Only slight adjustments should be made to the thermostat at any time. A 1/16 turn on the thermostat will change the water temp. 7° F (4° C). 44°F (7° C) in the trough represents the most economical operation. Counter clockwise raises the thermostat setting.

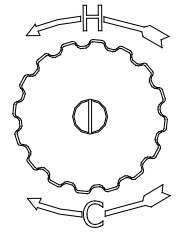

M. **Seal the Base** - After the unit is completely installed, apply a bead of caulking around the base of the fountain to ensure no wind enters through the base of the unit.

NOTE: *Sealing the bottom of the unit from cold air is an important aspect of the unit's thermal performance.*

N. **Drain Plug** – Insert the pre-assembled drain plugs firmly into the drain holes from inside the trough at each end. Wetting the plug can aid in installation.

O. **Valve Frame and Cover** – Before installing the valve chamber frame, the weather seal must be installed on the frame (right). The seal is installed by removing the paper backing from the adhesive side and then starting at the midpoint of the frame leg; attach the seal to the frame. Work your way around the frame with the seal as close to the inside edge as possible and then up the other leg to the halfway point. At this time cut any extra foam seal as needed then repeat for other side.

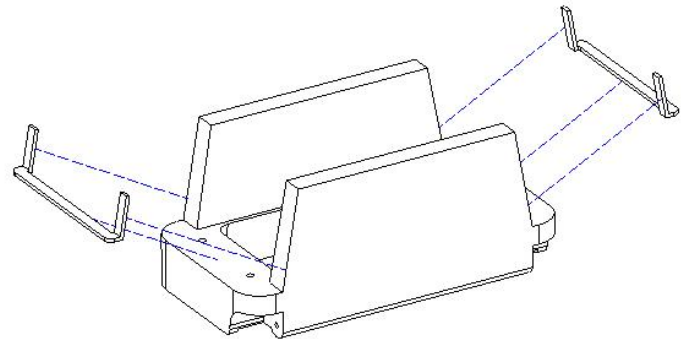

The frame can then be attached to the casing and trough using the T-bolts and nuts provided in parts bag. The T-Bolts slide into the four T-shaped holes (shown below) located near the center of each trough railing. Twisting the base of the T-bolt, once inserted, helps the bolt sit upright while installing the frame. A washer should be used on the head of the screw as well as under the nut. Tighten securely.

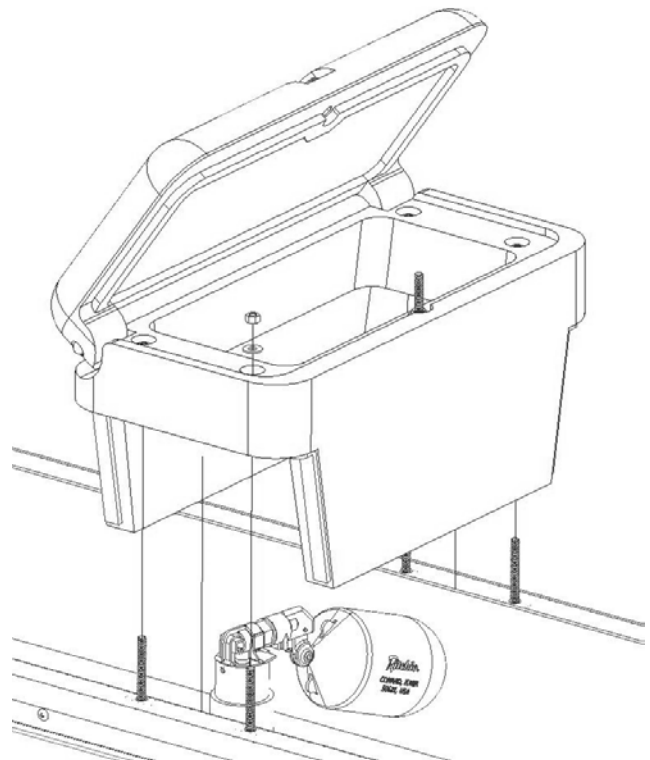
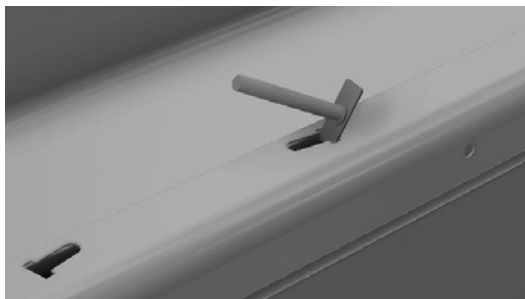

P. **Float Adjustment** – Open water-supply shut-off valve, check for and fix any leaks. Adjust float for a water depth of 2 inches below top of trough by adjusting the thumbscrew.

Q. **Install Side Access Panel and Close Lid**– Once all water line connections have been checked for leaks and electrical hook-up is complete, the side access door may be installed. After valve is checked to make sure it is functioning properly and the water level is set to the proper height, you may close and lock down the lid.

R. **Children should be supervised to ensure that they do not play with the appliance** – This appliance is not intended for use by persons (including children) with reduced physical, sensory or mental capabilities, or lack of experience and knowledge, unless they have been given supervision or instructions concerning use of the appliance by a person responsible for their safety.

S. **Cleaning Your Fountain** – To clean your watering fountain you will need a good stiff bristled brush. Open the hinged cover and brush the inside of the valve chamber to remove any build-up then brush the rest of fountain. Remove drain plugs to drain out the water and debris. You can shut off the water with the shut-off valve located under the unit or by holding the float in the up position. After the water and debris has drained reinstall the plugs and let the tank refill. Now is a good time to readjust the float if needed. Reinstall cover and you are done.

Ritchie Valves

Ritchie valves come in various sizes and pressure ratings as shown below - green for high supply line pressure, red for moderate supply pressure, and white for low-pressure applications. Differences in the size of trough also impacts valve choice. Although different pressure rated valves may be used in a fountain, each fountain will only accommodate one size and configuration of valve. Your individual situations may require a change from the standard valve supplied with your fountain, see your Ritchie Dealer if this is needed.

NOTE: *The green 3/4" valve is standard on the OmniMaster 8.*

3/4"	Part #	GPM	Pressure Range
White	16697	33	Low, 5-40 psi (34-275 kPa)
Red	11101	20	Moderate, 40-60 psi (275-414 kPa)
Green	15377	16.5	High, 60-80 psi (414-552 kPa)

NOTE: *Maximum inlet water pressure for each valve is shown above. If water pressure is extremely high, and if the valve does not shut off, a pressure-reducing valve may be needed.*

Trouble Shooting

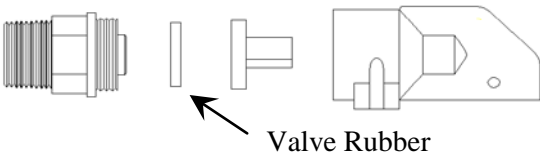
Problem	Solution
Water in Trough Too Warm	Adjust thermostat to lower temperature
	Check to see if thermostat has failed by contacts burning closed
Ice in Trough	Check fuses or circuit breakers
	Check all heating elements to make sure they are working and hot
	Adjust thermostat to higher temperature
	Check for voltage from thermostat output
	Check voltage to fountain with and without electrical load
	Check that heaters are wired properly
Valve Freezing	Check that cable heater is installed properly and fastened to water supply line and is working when heaters are hot
	Check for missing or damaged insulation
	Check for air gaps for wind penetrations
Supply line Freezing	Check that the cable heater is uncoiled and fastened around valve, to supply line and is working when heaters are hot
	Check that supply piping is centered in riser tube
	Check that riser tube is free of water and mud that may freeze
	Check that flexible hose does not touch side of casing or frame
	Check casing for air leaks
	Check for air gaps between casing and concrete floor
Valve won't stop dripping	Check float adjustment. Check for waterlogged float, or float rubbing on side of valve compartment
	Check for excessive system water pressure
	Disassemble valve and check for sand or scale in valve rubber. Also check valve orifice outlet for wear and damage. A screen or filter may be required with sandy or scaly water
	Turn valve rubber over and re-assemble
<p>3/4" Valve:</p>  <p style="text-align: center;">Valve Rubber</p>	
Low water flow	Check that valve inlet is not plugged or supply hose is not kinked
	Check system pressure from supply hose by installing a tee and a pressure gauge directly in front of the valve to check pressure drop when valve is open. A severe pressure drop indicates a restriction or undersized supply system.
	Check that shutoff valves are fully open

OmniMaster 8

Part # 18860

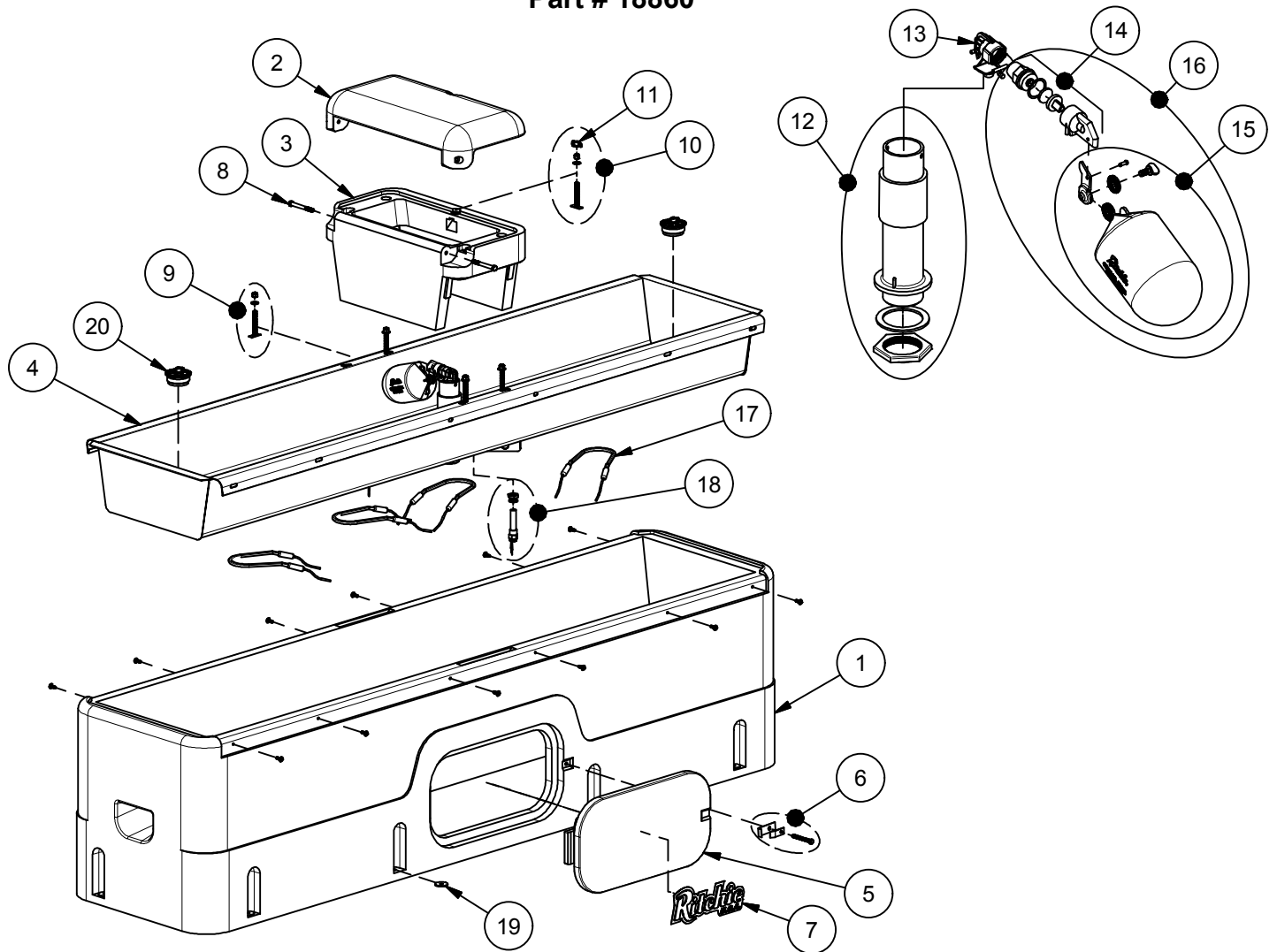

Item	Part #	Description	Qty	Item	Part #	Description	Qty
1	18851	OM 8 Casing	1	16	16993	Green Valve & Float pkg	1 pkg
2	18871	OM 8 Cover	1	17	11419	Heater 120V 250W (1/pkg)	4 pkg
3	18868	OM 8 Frame	1	18	16534	Fenwal Thermostat SS pkg	1 pkg
4	18872	OM 8 Trough Complete	1		18320	O-Ring Fenwal (6/pkg)	1 pkg
5	16562	Access Panel 10" x 20"	1		18074	Nut Brass Fenwal (6/pkg)	1 pkg
6	18147	Access Panel Hardware Pkg	1	19	18318	Bolt Down Washer (4/pkg)	2 pkg
7	18653	Ritchie Decal 12" (1/pkg)	1 pkg	20	18853	Drain Plug Ritchie 3" Short	2
8	18452	Bolt 3/8" x 3" SS (2/pkg)	1 pkg	NS	14866	Seal Foam 10' Roll	3
9	18854	OM 8 Frame Screws	1 pkg	NS	15931	Hose Clamp 1" SS (5/pkg)	1 pkg
10	18448	T-Bolt w/Wingnut 3/8" pkg	1 pkg	NS	18614	Adapter 3/4" x 5/8" HB	1 pkg
11	18451	Wing Nut 3/8" Nylon (4/pkg)	1 pkg	NS	18863	OM 8 Accessory pkg	1 pkg
12	18181	CM Standpipe Pkg	1 pkg	NS	13830	Cable Htr 120V 48W (1/pkg)	1 pkg
13	11514	Valve Bracket 3/4"	1 pkg				
14	15377	Green Male Valve 3/4" pkg	1 pkg		18861	OmniMaster 8 240V	
15	18314	Float with Hardware pkg	1 pkg	NS	11403	Heater 240V 300W (1/pkg)	3 pkg
	18313	Hardware for Float pkg	1 pkg	NS	16424	Cable Htr 240V 48W (1/pkg)	1 pkg

Ritchie Limited Warranty

Effective September 2012

Ritchie Industries, Inc. warrants its products to be free of defective materials and workmanship. Defective part(s) will be repaired or replaced at the option of Ritchie Industries. **This warranty specifically excludes all labor and shipping charges.**

This warranty does not apply to any appearance items, to any product whose exterior has been damaged or defaced, to any product that has been improperly installed, to any product subjected to misuse, abnormal service or handling, and to any products altered or repaired with other than original equipment or manufacturer's parts.

This warranty gives you specific legal rights, and you may also have other rights which vary from state to state.

All warranty claims must be processed through an Authorized Ritchie Dealer/ Distributor. **Proof of purchase is required. This warranty is not transferable.** The period of warranty begins at original date of purchase as follows:

Poly Units

Base, top and ball closures:

10 year limited against manufacturing defect. 100% first five years, then declining 20% per year for the remaining five years.

Stainless Steel Units

Stainless trough and stainless valve chamber frame:

Ten years against manufacturing defect or corrosion. 100% all ten years.

Casing and cover:

10 year limited against manufacturing defect. 100% first year, then declining 10% per year for the remaining nine years.

Component Parts

All component parts, such as floats, valves, heating elements:

One year from the date of purchase against manufacturing defect, 100%.